

This drawing is the sole property of Miether Bearing Products and contains confidential and proprietary information. It is being provided to you for your use and may not be disclosed to any third party or used for any other purpose without Miether's prior written consent. The [materials] must be returned to the Company upon its demand. Your acceptance of these materials constitutes your acceptance of the foregoing terms.

C-35217

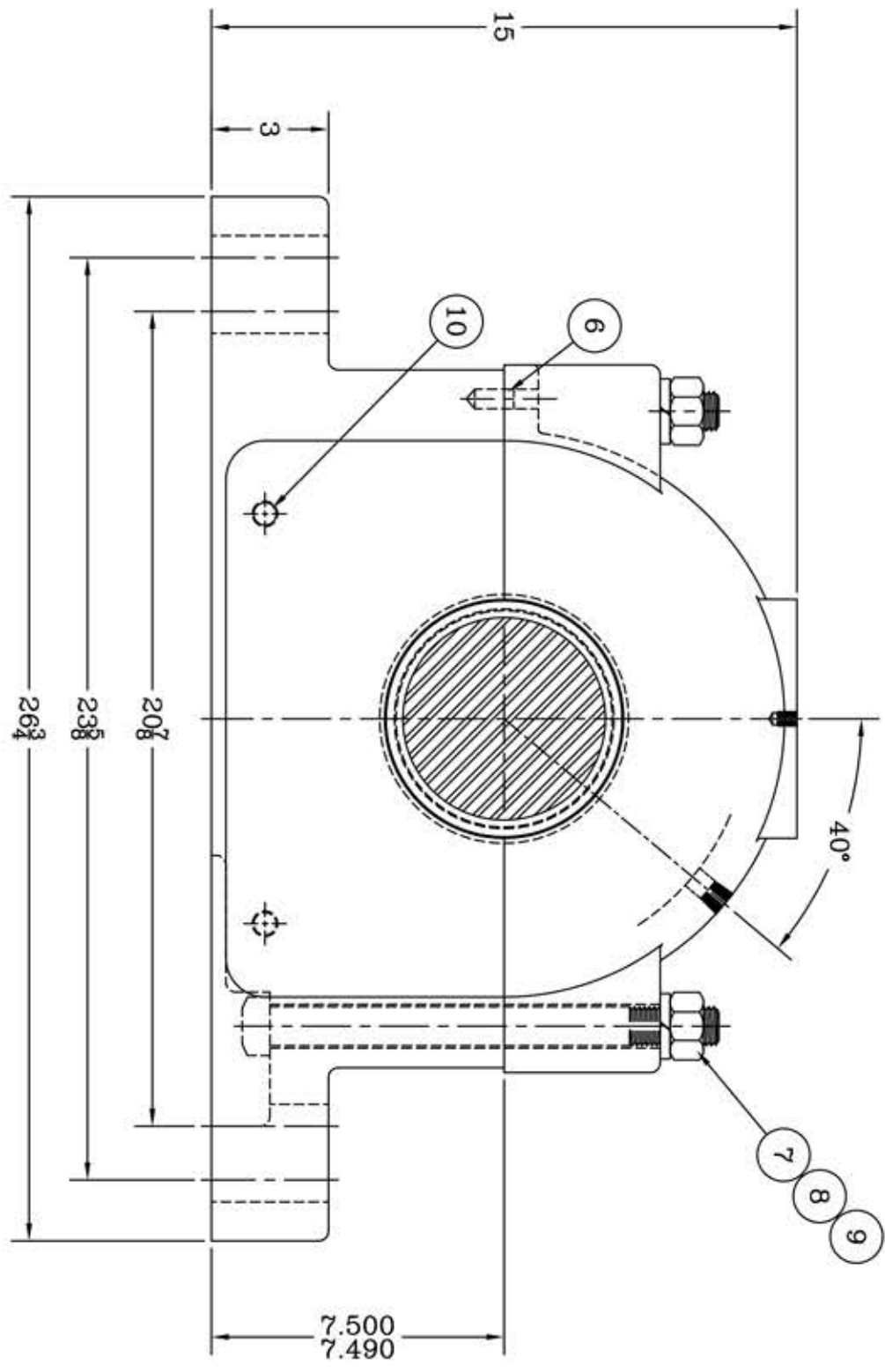

ITEM	DESCRIPTION	DETAIL	REQUIRED
1	HOUSING SAFD 630 05-03	C-	1 1
2	SPHERICAL ROLLER BEARING	22330K/W-33	1 1
3	STABILIZING RING SR-36-30	A-10610	1 0
4	ADAPTER SNW-12-30 05-03	24469	1 1
5	TRIPLE SEAL RING LER-125	A-10581	2 2
6	DOWEL	$\phi \frac{1}{2}$ x 1" LONG	2 2
7	CAP BOLT SQUARE HEAD GR.5	1-8 NC x $1\frac{1}{2}$ LONG	4 4
8	CAP BOLT HEX. NUT	1-8 NC	4 4
9	LOCKWASHER	1" SPLIT MED.	4 4
10	PIPE PLUG	$\frac{3}{8}$ -18 NPT	3 3

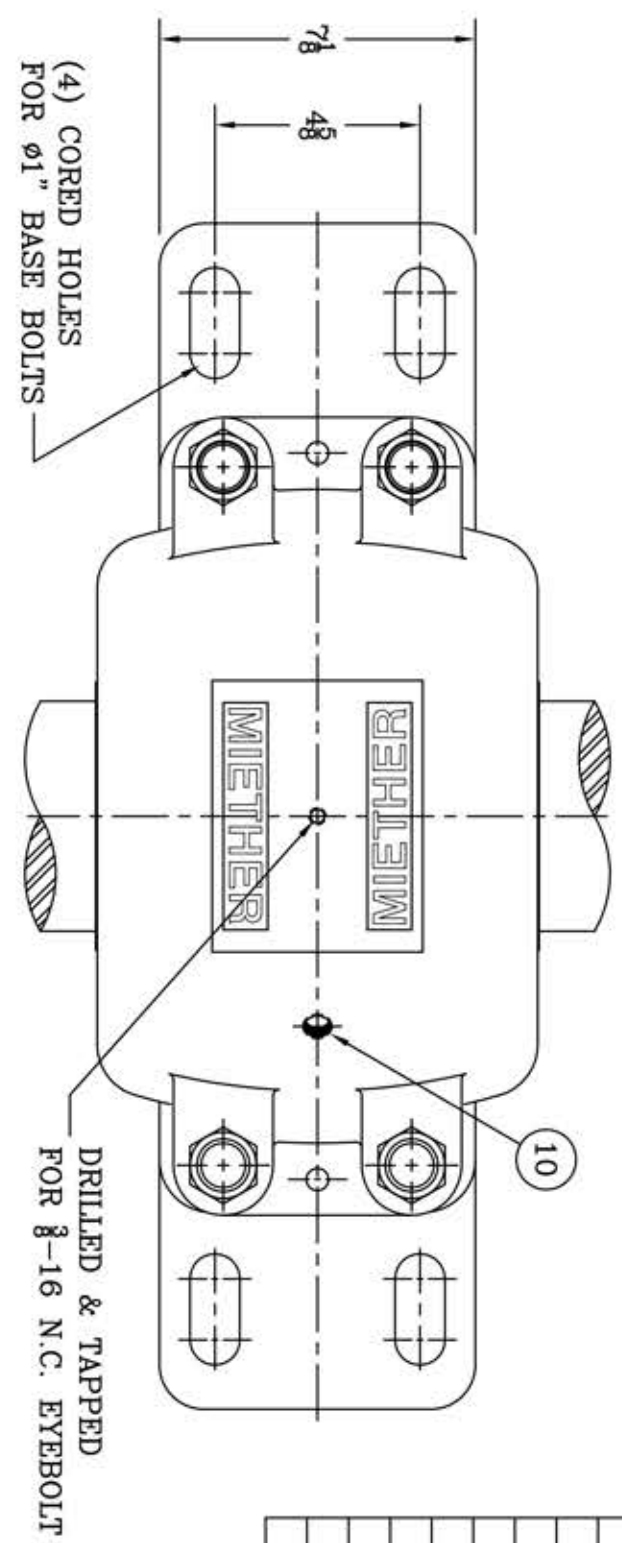
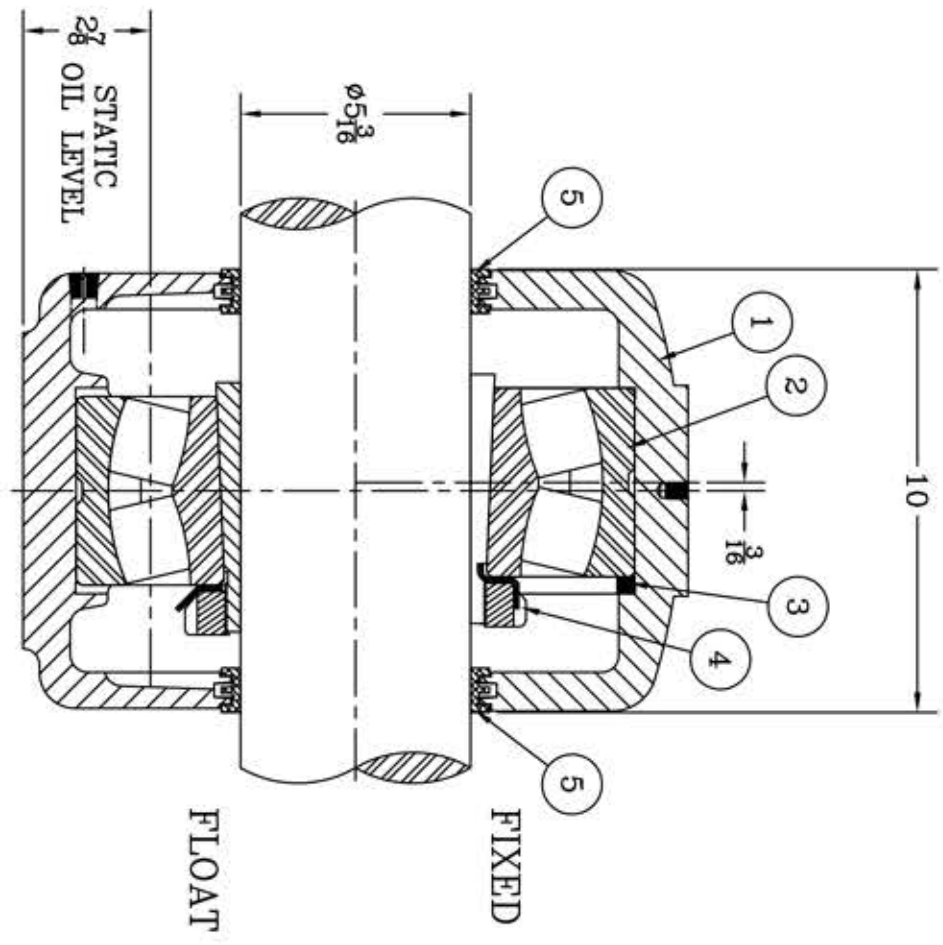

REVISIONS

SYMBOL	DESCRIPTION
C	16
D	32
E	63
F	125
G	250
J	500
K	1000

TOLERANCE: UNLESS OTHERWISE SPECIFIED
 FRACTIONS $\pm 1/32$ " ANGLES $\pm 0^\circ 30'$
 DECIMALS $\pm .005$ WELD $\pm 1/16$ "
 CASTING $\pm 1/16$ "

A.I.S.I. STANDARD FINISHES

AN ALCO INDUSTRIES COMPANY
 BEARING PRODUCTS
 ODESSA, TX. USA

SAFD 22630 05-03	ASSEMBLY NO.
ASSEMBLY DRAWING	SCALE 1 = 3
DRAWN PCF	DATE 1/2/13
DATE 1/2/13	DRAWING NO. C-35217
CHK:	